

DAY TWENTY FIVE

Alternating Current

Learning & Revision for the Day

- Peak and RMS Values of Alternating Current/Voltage
- Different Types of AC Circuits
- Series AC Circuits
- Quality Factor
- L-C Oscillations
- Power in an AC Circuit
- Wattless Current
- Choke Coil
- AC Generator
- Transformer

An **alternating current** is the current (or voltage) whose magnitude keeps on changing continuously with time, between zero and a maximum value and its direction also reverses periodically.

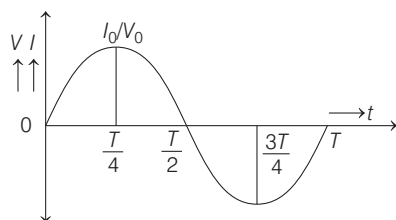

Peak and RMS Values of Alternating Current/ Voltage

Mean Value or Average Value or Peak Value

The steady current, which when passes through a circuit for half the time period of alternating current, sends the same amount of charge as done by the alternating current in the same time through the same circuit, is called mean or average value of alternating current. It is denoted by i_m or i_{av}

Thus,
$$i_m \text{ or } i_{av} = \frac{2i_0}{\pi} = 0.636 i_0$$

Thus, mean or average value of alternating current during a half cycle is 0.636 times (or 63.6% of) its peak value (i_0). Similarly, mean or average value of alternating emf

$$V_m \text{ or } V_{av} = \frac{2V_0}{\pi} = 0.636 V_0$$

RMS Value

The steady current, which when passes through a resistance for a given time will produce the same amount of heat as the alternating current does in the same resistance and in the same time, is called rms value of alternating current. It is denoted by i_{rms} or $i_v = \frac{i_0}{\sqrt{2}} = 0.707 i_0$

where, i_0 = peak value of alternating current

Similarly, rms value of alternating emf

$$V_{\text{rms}} = \frac{V_0}{\sqrt{2}} = 0.707 V_0$$

Reactance and Impedance

- The opposition offered by a pure inductor or capacitor or both to the flow of AC, through it, is called **reactance** (X). Its unit is ohm (Ω) and dimensional formula is $[ML^2 T^{-3} A^{-2}]$.

- Reactance is of two types**

(i) Inductive reactance, $X_L = L\omega$ and

(ii) Capacitive reactance, $X_C = \frac{1}{C\omega}$

- Reciprocal of reactance is known as **susceptance**.

Thus, $S = \frac{1}{X}$

- Total opposition offered by an AC circuit to the flow of current through it, is called its **impedance** (Z). Its unit is ohm and dimensional formula is $[ML^2 T^{-3} A^{-2}]$.

For an AC circuit, $Z = \sqrt{X^2 + R^2} = \sqrt{(X_L - X_C)^2 + R^2}$

- Reciprocal of impedance is known as **admittance**.

Thus, $Y = \frac{1}{Z}$. Its unit is Siemens (S).

Different Types of AC Circuits

The circuit consists of resistor, capacitor and inductor are called pure resistive, pure inductive and pure capacitive circuit.

1. Pure Resistive Circuit

Let an alternating voltage $V = V_0 \sin \omega t$ be applied across a pure resistance R . Then,

Current, $I = \frac{V}{R}$ or $I_{\text{rms}} = \frac{V_{\text{rms}}}{R}$

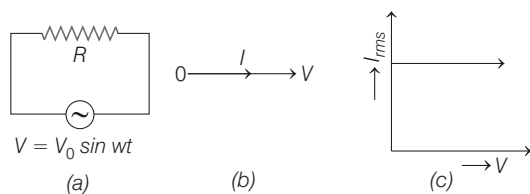

Current and voltage are in the same phase, i.e. current is given by $I = I_0 \sin \omega t$.

2. Pure Inductive Circuit

Let an alternating voltage $V = V_0 \sin \omega t$ be applied across a pure inductance L .

Then, the average power = $V_{\text{rms}} I_{\text{rms}} \cos \frac{\pi}{2} = 0$

The inductance offers some opposition to the flow of AC, known as **inductive reactance** $X_L = 2\pi\nu L = L\omega$.

Thus, a pure inductance does not oppose the flow of DC ($\omega = 0$) but opposes the flow of AC.

Current flowing, $I = \frac{V}{X_L}$

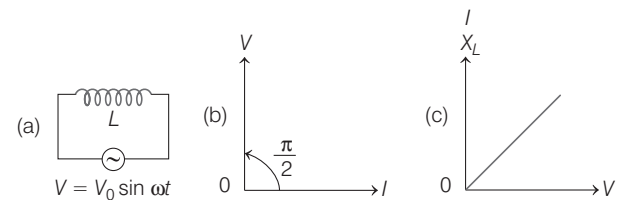

In pure inductive circuit, current decreases with an increase in frequency, it lags behind the voltage by $\frac{\pi}{2}$

(or voltage leads the current by $\frac{\pi}{2}$) and is thus given by

$$I = I_0 \sin \left(\omega t - \frac{\pi}{2} \right)$$

3. Pure Capacitive Circuit

Let an alternating voltage $V = V_0 \sin \omega t$ be applied across a pure capacitance C . Then, the capacitance offers some opposition to the flow of current, but allows AC to pass through it. The opposition offered is known as the **capacitive reactance**.

$$X_C = \frac{1}{C\omega} \Omega$$

$$= \frac{1}{C \times 2\pi\nu} \Omega$$

Current flowing, $I = \frac{V}{X_C}$

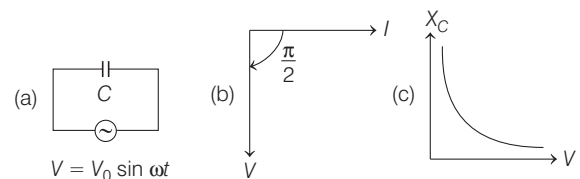

In pure capacitive circuit, current increases with an increase in frequency and leads the voltage by $\frac{\pi}{2}$

(or voltage lags behind the current by $\frac{\pi}{2}$) and is thus, given by

$$I = I_0 \sin \left(\omega t + \frac{\pi}{2} \right)$$

Series AC Circuits

Some of the series AC circuits are given below

1. Series L-R Circuit

The potential difference across the resistance in an AC circuit is in phase with current and it leads in phase by 90° with current across the inductor.

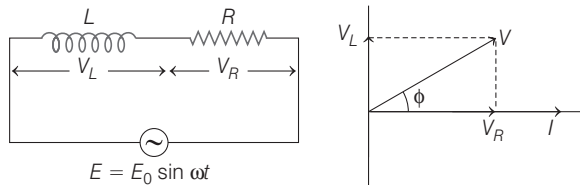

$$E = E_0 \sin \omega t \text{ and } I = \frac{E_0}{Z} \sin(\omega t - \phi)$$

where, $Z = \sqrt{R^2 + (\omega L)^2}$

Current lags behind the voltage by ϕ .

and $\tan \phi = \frac{\omega L}{R}$

$\therefore V = \sqrt{V_R^2 + V_L^2}$

where, V_R = voltage across resistor R

and V_L = voltage across inductor.

2. Series R-C Circuit

The potential difference across a resistance in AC circuit is in phase with current and it lags in phase by 90° with the current in the capacitor.

$$E = E_0 \sin \omega t$$

and $I = \frac{E_0}{Z} \sin(\omega t + \phi)$

where, $Z = \sqrt{R^2 + \left(\frac{1}{\omega C}\right)^2}$

Current leads the voltage by ϕ .

and $\tan \phi = \frac{-1/\omega C}{R}$

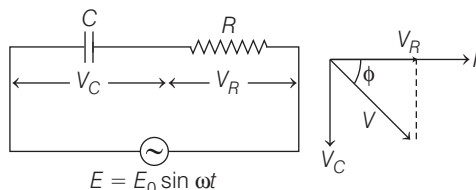

$\therefore V = \sqrt{V_R^2 + V_C^2}$

where, V_R = voltage across resistor R

and V_C = voltage across capacitor.

3. Series L-C Circuit

The potential difference across a capacitor in AC lags in phase by 90° and leads in phase by 90° by inductance with the current in the circuit.

$$E = E_0 \sin \omega t, I = \frac{E_0}{Z} \sin(\omega t - \phi)$$

where, $Z = X_L - X_C$ and $\tan \phi = \frac{X_L - X_C}{0} = \infty$

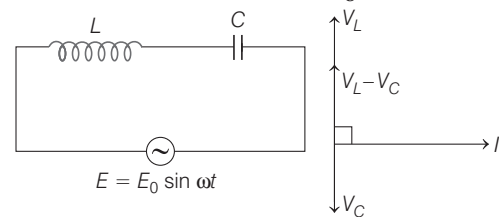

For $X_L > X_C$, $\phi = \frac{\pi}{2}$ and for $X_L < X_C$, $\phi = -\frac{\pi}{2}$

If $X_L = X_C$ i.e. at $\omega = \frac{1}{\sqrt{LC}}$, $Z = 0$ and I_0 becomes infinity.

This condition is termed as the **resonant condition** and this frequency is termed as natural frequency of the circuit.

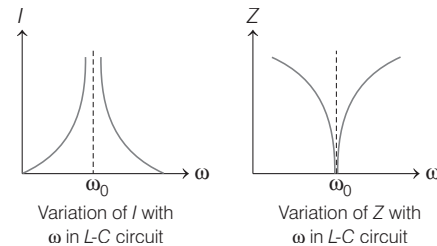

4. Series L-C-R Circuit

For L-C-R circuit $E = E_0 \sin \omega t, I = \frac{E_0}{Z} \sin(\omega t - \phi)$

where, $Z = \sqrt{R^2 + \left(\omega L - \frac{1}{\omega C}\right)^2}$

and $\tan \phi = \frac{X}{R} = \frac{X_L - X_C}{R}$

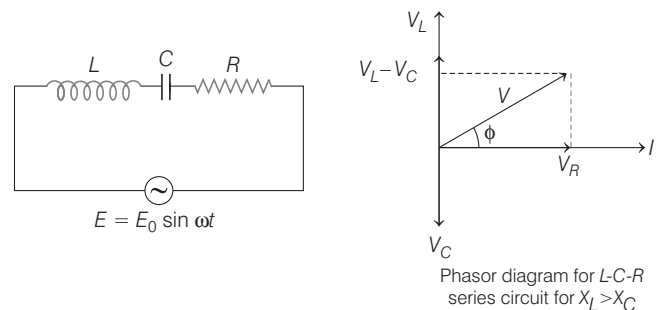

For $X_L > X_C$, current lags voltage.

$X_L < X_C$, current leads voltage.

$X_L = X_C$, current and voltage are in phase.

If $X_L = X_C \Rightarrow \omega_0 = \frac{1}{\sqrt{LC}}$, i.e. the natural frequency of the circuit is equal to the applied frequency, then the circuit is said to be in **resonance**.

At resonance, the current in the circuit is maximum and the impedance is minimum.

$$\text{Resonance frequency, } \nu = \frac{1}{2\pi\sqrt{LC}}$$

Quality Factor

The Q-factor or quality factor of a resonant L-C-R circuit is defined as ratio of the voltage drop across inductor (or capacitor) to applied voltage. Thus,

$$Q = \frac{\text{voltage across } L \text{ (or } C)}{\text{applied voltage}}$$

$$Q = \frac{1}{R} \sqrt{\frac{L}{C}}$$

L-C Oscillations

An L-C circuit also called a resonant circuit, tank circuit or tuned circuit. When connected together, they can act as an electrical resonator, storing energy oscillating at the circuits resonant frequency.

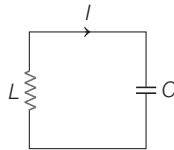

The energy oscillates back and forth between the capacitor and inductor until internal resistance makes the oscillations die out. The oscillation frequency is determined by the capacitance and inductance values,

$$f = \frac{\omega_0}{2\pi} = \frac{1}{2\pi\sqrt{LC}}$$

Power in an AC Circuit

Let a voltage $V = V_0 \sin \omega t$ be applied across an AC and consequently a current $I = I_0 \sin(\omega t - \phi)$ flows through the circuit. Then,

- **Instantaneous power** $= VI = V_0 I_0 \sin \omega t \sin(\omega t - \phi)$ and its value varies with time. Here, ϕ is known as **phase difference** between V and I .
- **Average power** over a full cycle of AC is

$$P_{av} = V_{rms} I_{rms} \cos \phi = \frac{1}{2} V_0 I_0 \cos \phi$$

The term $V_{rms} I_{rms}$ is known as the **apparent** or **virtual power**, but $V_{rms} I_{rms} \cos \phi$ is called the **true power**.

- The term $\cos \phi$ is known as the **power factor** of the given circuit. Thus,

$$\begin{aligned} \cos \phi &= \frac{R}{Z} = \text{power factor} \\ &= \frac{\text{true power}}{\text{apparent power}} \end{aligned}$$

- For a pure resistive circuit, V and I are in phase ($\phi = 0^\circ$), hence $\cos \phi = 1$ and average power $= V_{rms} I_{rms}$
- For a pure inductive or a pure capacitive circuit, current and voltage differ in phase by $\frac{\pi}{2}$ (i.e. $\phi = \frac{\pi}{2}$).
- Power loss $= I^2 R = \frac{V^2}{R}$

Wattless Current

Average power is given by $P_{av} = E_{rms} I_{rms} \cos \phi$

The phase difference between E_{rms} and I_{rms} is ϕ . We can resolve I_{rms} into two components

$$I_{rms} \cos \phi \text{ and } I_{rms} \sin \phi$$

Here, the component $I_{rms} \cos \phi$ contributes towards power dissipation and the component $I_{rms} \sin \phi$ does not contribute towards power dissipation. Therefore, it is called **wattless current**.

Choke Coil

A low resistance inductor coil used to suppress or limit the flow of alternating current without affecting the flow of direct current is called **choke coil**.

Let us consider a choke coil (used in tube lights) of large inductance L and low resistance R . The power factor for such a coil is given by

$$\cos \phi = \frac{R}{\sqrt{R^2 + \omega^2 L^2}} \approx \frac{R}{\omega L} \quad [\text{as, } R \ll \omega L]$$

As $R \ll \omega L$, $\cos \phi$ is very small. Thus, the power absorbed by the coil $V_{rms} I_{rms} \cos \phi$ is very small. On account of its large impedance $Z = \sqrt{R^2 + \omega^2 L^2}$, the current passing through the coil is very small. Such a coil is used in AC circuits for the purpose of adjusting current to any required value without wastage of energy.

The only loss of energy is due to hysteresis in the iron core, which is much less than the loss of energy in the resistance that can also reduce the current, if placed instead of the choke coil.

AC Generator

An electric generator or dynamo is a device used to produce electrical energy at the expense of mechanical/thermal energy.

It works on the principle of electromagnetic induction, when a coil is rotated in a uniform magnetic field, an induced emf is set up between its ends. The induced emf is given by

$$e = e_0 \sin \omega t = NBA \omega \sin \omega t.$$

The direction of the induced emf is alternating in nature.

Transformer

It is a device which works in AC circuits only and is based on the principle of mutual induction.

Transformer is used to suitably increase or decrease the voltage in an AC circuit. Transformer which transforms strong AC at low voltage into a weaker current at high alternating voltage is called a step-up transformer. A step-down transformer transforms weak current at a higher alternating voltage into a strong current at a lower alternating voltage.

For an **ideal transformer** $\frac{e_s}{e_p} = \frac{V_s}{V_p} = \frac{N_s}{N_p} = \frac{I_p}{I_s} = k$

where, k is known as the transformation ratio.

For a step-up transformer, $k > 1$ but for a step-down transformer, $k < 1$.

In a transformer, the input emf and the output emf differ in phase by π radians.

The **efficiency of a transformer** is given by

$$\eta = \frac{\text{output power}}{\text{input power}} = \frac{V_s I_s}{V_p I_p}$$

For an ideal transformer, $\eta = 100\%$ or 1. However, for practical transformers, $\eta \approx 85 - 90\%$.

Possible causes of energy loss in transformer are

- Heating due to winding resistance
- Eddy current losses
- Magnetic flux leakage and
- Hysteresis loss. To minimise these losses, the transformer core is made up of a laminated soft iron strips.

DAY PRACTICE SESSION 1

FOUNDATION QUESTIONS EXERCISE

- 1 The electric current in a circuit is given by $I = 3t$

Here, t is in second, I is in ampere. The rms current for the period $t = 0$ to $t = 1$ s is

- (a) 3 A (b) 9 A (c) $\sqrt{3}$ A (d) $3\sqrt{3}$ A

- 2 If the rms current in a 50 Hz AC circuit is 5 A, the value of the current $1/300$ s after its value becomes zero is

- (a) $5\sqrt{2}$ A (b) $5\sqrt{3/2}$ A (c) $5/6$ A (d) $5/\sqrt{2}$ A

- 3 Through which of the AC circuit elements, both the emf and current are in phase?

- (a) Impedance (b) Inductive reactance
(c) Capacitive reactance (d) Resistance

- 4 The electric mains in the house is marked 220 V, 50 Hz. Write down the equation for instantaneous voltage.

- (a) $3.1V \sin(100\pi)t$ (b) $31.1V \cos(100\pi)t$
(c) $311.1V \sin(100\pi)t$ (d) $311.1V \cos(100\pi)t$

- 5 In an AC circuit, an alternating voltage $e = 200\sqrt{2} \sin 100t$ volt is connected to a capacitor of capacity $1 \mu\text{F}$. The rms value of the current in the circuit is → CBSE AIPMT 2011

- (a) 100 mA (b) 200 mA (c) 20 mA (d) 10 mA

- 6 If emf $E = 4 \cos 1000t$ volt is applied to an L - R circuit of inductance 3 mH and resistance 4Ω , the amplitude of current in the circuit is

- (a) $\frac{4}{\sqrt{7}}$ A (b) 1.0 A
(c) $\frac{4}{7}$ A (d) 0.8 A

- 7 An AC voltage is applied to a resistance R and an inductor L in series. If R and the inductive reactance are both equal to 3Ω , the phase difference between the applied voltage and the current in the circuit is

→ CBSE AIPMT 2011

- (a) $\frac{\pi}{4}$ rad (b) $\frac{\pi}{2}$ rad (c) zero (d) $\frac{\pi}{6}$ rad

- 8 A 100Ω resistance and a capacitor of 100Ω reactance are connected in series across a 220 V source. When the capacitor is 50% charged, the peak value of the displacement current is → NEET 2016

- (a) 2.2 A (b) 11 A (c) 4.4 A (d) $11\sqrt{2}$ A

- 9 In an L - C - R series circuit, the potential difference between the terminals of the inductance is 60 V, between the terminals of the capacitor is 30 V and that across the resistance is 40 V. Then, supply voltage will be equal to

- (a) 50 V (b) 70 V (c) 130 V (d) 10 V

- 10 In the given circuit, the reading of voltmeter V_1 and V_2 are 300 V each. The reading to the voltmeter V_3 and ammeter A are respectively → CBSE AIPMT 2010

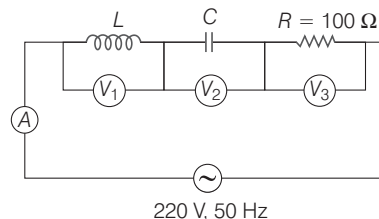

- (a) 150 V, 2.2 A (b) 220 V, 2.2 A
(c) 220 V, 2.0 A (d) 100 V, 2.0 A

- 11 What is the value of inductance L for which the current is maximum in a series L - C - R circuit with $C = 10 \mu\text{F}$ and $\omega = 1000 \text{ s}^{-1}$?

- (a) 100 mH
(b) 1 mH
(c) Cannot be calculated unless R is known
(d) 10 mH

12 An AC circuit contains a resistance R , capacitance C and inductance L in series with a source of emf $E = E_0 \sin(\omega t + \phi)$. The current through the circuit is maximum, when

- (a) $R = L = C$ (b) $\omega L = \frac{1}{\omega C}$ (c) $\omega^2 = LC$ (d) $\omega = RLC$

13 The bandwidth of a series resonant circuit is 500 Hz and the resonant frequency is 5000 Hz. The quality factor of the circuit will be

- (a) 40 (b) 20 (c) 10 (d) 5

14 Which of the following combinations should be selected for better tuning of an L - C - R circuit used for communication? → NEET 2016

- (a) $R = 20\Omega, L = 15\text{ H}, C = 35\ \mu\text{F}$
 (b) $R = 25\Omega, L = 2.5\text{ H}, C = 45\ \mu\text{F}$
 (c) $R = 15\Omega, L = 3.5\text{ H}, C = 30\ \mu\text{F}$
 (d) $R = 25\Omega, L = 15\text{ H}, C = 45\ \mu\text{F}$

15 A condenser of capacitance of $2.4\ \mu\text{F}$ is used in transmitter to transmit at λ wavelength. If the inductor of 10^{-8} H is used for resonant circuit, then value of λ is
 (a) 292 m (b) 400 m (c) 334 m (d) 446 m

16 A transmitter transmits at a wavelength of 300 m. A condenser of capacitance $2.4\ \mu\text{F}$ is being used. The value of the inductance for the resonant circuit is approximately
 (a) 10^{-4} H (b) 10^{-6} H (c) 10^{-8} H (d) 10^{-10} H

17 By what percentage, the impedance in AC series circuit should be increased, so that the power factor changes from $(1/2)$ to $(1/4)$ (when R is constant)?
 (a) 200% (b) 100% (c) 50% (d) 400%

18 A small signal voltage $V(t) = V_0 \sin \omega t$ is applied across an ideal capacitor C → NEET 2016

- (a) over a full cycle the capacitor C does not consume any energy from the voltage source
 (b) current $I(t)$ is in phase with voltage $V(t)$
 (c) current $I(t)$, leads voltage $V(t)$ by 180°
 (d) current $I(t)$, lags voltage $V(t)$ by 90°

19 Power dissipated in an L - C - R series circuit connected to an AC source of emf ϵ is → CBSE AIPMT 2009

- (a) $\frac{\epsilon^2 R}{R^2 + \left(L\omega - \frac{1}{C\omega}\right)^2}$ (b) $\frac{\epsilon^2 R}{\sqrt{R^2 + \left(L\omega - \frac{1}{C\omega}\right)^2}}$
 (c) $\frac{\epsilon^2 \left[R^2 + \left(L\omega - \frac{1}{C\omega}\right)^2\right]}{R}$ (d) $\frac{\epsilon^2 \sqrt{R^2 + \left(L\omega - \frac{1}{C\omega}\right)^2}}{R}$

20 The instantaneous values of alternating current and voltages in a circuit are given as

$$I = \frac{1}{\sqrt{2}} \sin(100\pi t) \text{ ampere}$$

$$e = \frac{1}{\sqrt{2}} \sin(100\pi t + \pi/3) \text{ volt}$$

The average power (in watts) consumed in the circuit is

→ CBSE AIPMT 2013

- (a) $\frac{1}{4}$ (b) $\frac{\sqrt{3}}{4}$
 (c) $\frac{1}{2}$ (d) $\frac{1}{8}$

21 The potential differences across the resistance, capacitance and inductance are 80 V, 40 V and 100 V respectively in an L - C - R circuit. The power factor of this circuit is → NEET 2016

- (a) 0.4 (b) 0.5
 (c) 0.8 (d) 1.0

22 An AC ammeter is used to measure current in a circuit. When a given direct current passes through the circuit, the AC ammeter reads 3 A. When another alternating current passes through the circuit, the AC ammeter reads 4A. Then, the reading of this ammeter, if DC and AC flow through the circuit simultaneously, is

- (a) 3 A (b) 4 A
 (c) 7 A (d) 5 A

23 An inductor of reactance $1\ \Omega$ and a resistor of $2\ \Omega$ are connected in series to the terminals of a 6 V (rms) AC source. The power dissipated in the circuit is

- (a) 8 W (b) 12 W
 (c) 14.4 W (d) 18 W

24 A transformer having efficiency of 90% is working on 200 V and 3 kW powers supply. If the current in the secondary coil is 6 A, the voltage across the secondary coil and the current in the primary coil respectively are

→ CBSE AIPMT 2014

- (a) 300 V, 15 A (b) 450 V, 15 A
 (c) 450 V, 13.5 A (d) 600 V, 15 A

25 A 220 V input is supplied to a transformer. The output circuit draws a current of 2.0 A at 440 V. If the efficiency of the transformer is 80%, the current drawn by the primary windings of the transformer is → CBSE AIPMT 2010

- (a) 3.6 A (b) 2.8 A
 (c) 2.5 A (d) 5.0 A

DAY PRACTICE SESSION 2

PROGRESSIVE QUESTIONS EXERCISE

1 An alternating voltage $V = 30 \sin 50t + 40 \cos 50t$ is applied to a resistor of resistance 10Ω . The rms value of current through resistor is

- (a) $\frac{5}{\sqrt{2}}$ A (b) $\frac{10}{\sqrt{2}}$ A (c) $\frac{7}{\sqrt{2}}$ A (d) 7 A

2 One 10 V, bulb of 60 W is to be connected to 100 V line. The required self-inductance of induction coil will be (Take, $f = 50$ Hz)

- (a) 0.052 H (b) 2.42 H (c) 16.2 H (d) 16.2 mH

3 An AC source is connected with a resistance R and an uncharged capacitance C in series.

The potential difference across the resistor is in phase with the initial potential difference across the capacitor for the first time at the instant (assume that, at $t = 0$, emf is zero)

- (a) $\frac{\pi}{4\omega}$ (b) $\frac{2\pi}{\omega}$ (c) $\frac{\pi}{2\omega}$ (d) $\frac{3\pi}{2\omega}$

4 An AC circuit having supply voltage E consists of a resistor of resistance 3Ω and an inductor of reactance 4Ω as shown in the figure. The voltage across the resistance at $t = \pi / \omega$ is

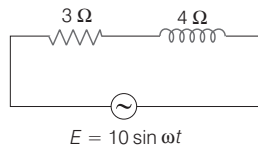

- (a) 6.4 V (b) 10 V (c) zero (d) 4.8 V

5 A coil of inductive reactance 31Ω has a resistance of 8Ω . It is placed in series with a condenser of capacitive reactance 25Ω . The combination is connected to an AC source of 110 V. The power factor of the circuit is

- (a) 0.56 (b) 0.64 (c) 0.80 (d) 0.33

6 The maximum current in the circuit, if a capacitor of capacitance $1 \mu\text{F}$ is charged to a potential of 2 V and is connected in parallel to an inductor of inductance 10^{-3} H is

- (a) $\sqrt{4000}$ mA (b) $\sqrt{2000}$ mA
(c) $\sqrt{1000}$ mA (d) $\sqrt{5000}$ mA

7 A resistance R draws power P when connected to an AC source. If an inductance is now placed in series with the resistance, such that the impedance of the circuit becomes Z , the power drawn will be → CBSE AIPMT 2015

- (a) $P_0 \left(\frac{R}{Z}\right)^2$ (b) $P_0 \sqrt{\frac{R}{Z}}$ (c) $P_0 \left(\frac{R}{Z}\right)$ (d) P_0

8 In an electrical circuit R, L, C and an AC voltage source are all connected in series. When L is removed from the circuit, the phase difference between the voltage and the current in the circuit is $\frac{\pi}{3}$. If instead, C is removed from

the circuit, the phase difference is again $\frac{\pi}{3}$. The power factor of the circuit is

→ CBSE AIPMT 2012

- (a) $\frac{1}{2}$ (b) $\frac{1}{\sqrt{2}}$ (c) 1 (d) $\frac{\sqrt{3}}{2}$

9 A coil of self-inductance L is connected in series with a bulb B and an AC source. Brightness of the bulb decreases when

→ NEET 2013

- (a) frequency of the AC source is decreased
(b) number of turns in the coil is reduced
(c) a capacitance of reactance $X_C = X_L$ is included in the same circuit
(d) an iron rod is inserted in the coil

10 An inductor 20 mH, a capacitor $50 \mu\text{F}$ and a resistor 40Ω are connected in series across a source of emf $V = 10 \sin 340t$. The power loss in AC circuit is

→ NEET 2016

- (a) 0.67 W (b) 0.76 W (c) 0.89 W (d) 0.51 W

11 In a circuit, L, C and R are connected in series with an alternating voltage source of frequency f . The current leads the voltage by 45° . The value of C is

- (a) $\frac{1}{2\pi f (2\pi f L + R)}$ (b) $\frac{1}{\pi f (2\pi f L + R)}$
(c) $\frac{1}{2\pi f (2\pi f L - R)}$ (d) $\frac{1}{\pi f (2\pi f L - R)}$

12 In the given AC circuit, when switch S is at position 1, the source emf leads current by $\frac{\pi}{6}$. Now, if the switch is at position 2, then

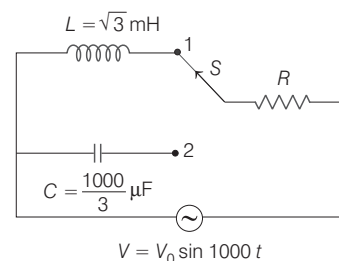

- (a) current leads source emf by $\frac{\pi}{3}$
(b) current leads source emf by $\frac{\pi}{4}$

- (c) source emf lead current by $\frac{\pi}{4}$
 (d) None of the above

13 As given in the figure, a series circuit connected across a 200 V, 60 Hz line consists of a capacitor of capacitive reactance 30Ω , a non-inductive resistor of 44Ω , and a coil of inductive reactance 90Ω and resistance 36Ω . The power dissipated in the coil is

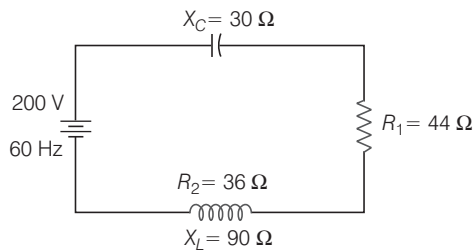

- (a) 320 W (b) 176 W
 (c) 144 W (d) 0 W

14 Figure shows a circuit that contains three identical resistors with resistance $R = 9.0 \Omega$ each, two identical inductors with inductance $L = 2.0 \text{ mH}$ each, and an ideal

battery with emf $\epsilon = 18 \text{ V}$. The current i through the battery just after the switch closed is **→ NEET 2017**

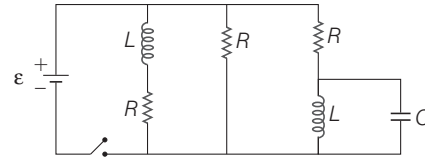

- (a) 2 mA (b) 0.2 A (c) 2 A (d) 0 A

15 A series R - C circuit is connected to an alternating voltage source. Consider two situations : **→ CBSE AIPMT 2015**

- When capacitor is air filled.
- When capacitor is mica filled.

Current through resistor is i and voltage across capacitor is V , then

- (a) $V_a < V_b$ (b) $V_a > V_b$ (c) $i_a > i_b$ (d) $V_a = V_b$

16 An inductor 20 mH , a capacitor $100 \mu\text{F}$ and a resistor 50Ω are connected in series across a source of emf, $V = 10 \sin 314 t$. The power loss in the circuit is **→ NEET 2018**

- (a) 2.74 W (b) 0.43 W (c) 0.79 W (d) 1.13 W

ANSWERS

SESSION 1	1 (c)	2 (b)	3 (d)	4 (a)	5 (c)	6 (d)	7 (a)	8 (a)	9 (a)	10 (b)
	11 (a)	12 (b)	13 (c)	14 (c)	15 (a)	16 (c)	17 (b)	18 (a)	19 (a)	20 (d)
	21 (c)	22 (d)	23 (c)	24 (b)	25 (d)					
SESSION 2	1 (a)	2 (a)	3 (d)	4 (d)	5 (c)	6 (a)	7 (a)	8 (c)	9 (d)	10 (d)
	11 (c)	12 (b)	13 (a)	14 (*)	15 (b)	16 (c)				

Hints and Explanations

SESSION 1

1 Given, $I = 3t \Rightarrow I^2 = 9t^2$

$$(I^2)_{0-1} = \int_0^1 9t^2 dt = 3$$

$$\therefore I_{\text{rms}} = \sqrt{3} \text{ A}$$

2 Here, $v = 50 \text{ Hz}$, $I_V = 5 \text{ A}$, $I = ?$, $t = \frac{1}{300} \text{ s}$

$$I_0 = \sqrt{2} I_V = \sqrt{2} \times 5 \text{ A}$$

$$\text{From } I = I_0 \sin \omega t$$

$$= 5\sqrt{2} \sin 100\pi \times \frac{1}{300}$$

$$= 5\sqrt{2} \times \frac{\sqrt{3}}{2} = 5\sqrt{3/2} \text{ A}$$

3 Through the resistance in the AC circuit, both the emf and current are in phase.

4 We are given that,

$$\epsilon_{\text{rms}} = 220 \text{ V}, v = 50 \text{ Hz}$$

$$\text{As, } \epsilon_{\text{rms}} = \frac{\epsilon_0}{\sqrt{2}}, \epsilon_0 = \epsilon_{\text{rms}} \sqrt{2}$$

$$(220 \text{ V}) (1.414) = 311.1 \text{ V}$$

Further,

$$\omega = 2\pi v = 2\pi \times 50 = 100 \pi \text{ rad/s}$$

Thus, the equation for the instantaneous voltage is given as

$$\epsilon = \epsilon_0 \sin \omega t = 311.1 \text{ V} \sin (100 \pi) t$$

5 We know that, $e = e_m \sin \omega t$

$$\text{where, } e_m = e_{\text{rms}}$$

$$\text{Given, emf, } e = 200 \sqrt{2} \sin 100 t$$

$$\text{and } C = 1 \mu\text{F} = 1 \times 10^{-6} \text{ F}$$

$$\text{As } e_{\text{rms}} = 200 \text{ V and } \omega = 100 \text{ s}^{-1}$$

$$\therefore X_C = \frac{1}{\omega C} = \frac{1}{100 \times 10^{-6}} = 10^4 \Omega$$

$$\therefore i_{\text{rms}} = \frac{e_{\text{rms}}}{X_C} = \frac{200}{10^4} = 2 \times 10^{-2} \text{ A} = 20 \text{ mA}$$

6 Impedance, $Z = \sqrt{R^2 + X_L^2}$

$$\text{Here, } R = 4 \Omega, X_L = L\omega$$

$$= 3 \times 10^{-3} \times 1000 \Omega = 3 \Omega$$

$$\text{Then, } Z = \sqrt{(4)^2 + (3)^2}$$

$$= \sqrt{16 + 9} = \sqrt{25} = 5 \Omega$$

$$\text{Hence, current, } I_0 = \frac{E_0}{Z} = \frac{4}{5} = 0.8 \text{ A}$$

$$7 \tan \phi = \frac{X_L}{R} = \frac{L\omega}{R} = \frac{3\Omega}{3\Omega}$$

$$\tan \phi = 1 \Rightarrow \phi = \tan^{-1}(1) = 45^\circ = \frac{\pi}{4} \text{ rad}$$

8 Impedence of the R-C circuit,

$$Z = \sqrt{R^2 + X_C^2}$$

where, $R = 100 \Omega$ and $X_C = 100 \Omega$

$$\Rightarrow Z = \sqrt{(100)^2 + (100)^2} = 100\sqrt{2} \Omega$$

Peak value of the current,

$$I_{\max} = \frac{V_{\max}}{Z} = \frac{220\sqrt{2}}{100\sqrt{2}} = 2.2 \text{ A}$$

9 In an L-C-R series circuit,

$$V = \sqrt{V_R^2 + (V_L - V_C)^2}$$

$$= \sqrt{(40)^2 + (60 - 30)^2}$$

$$= \sqrt{1600 + 900} = \sqrt{2500} = 50 \text{ V}$$

10 For series L-C-R circuit,

$$\text{Voltage, } V = \sqrt{V_R^2 + (V_L - V_C)^2}$$

Since, $V_L = V_C$

Hence, $V = V_R = 220 \text{ V}$

Also, current,

$$i = \frac{V}{R} = \frac{220}{100} = 2.2 \text{ A}$$

11 If $X_L = X_C$

This happens in resonance state of the circuit.

$$\text{i.e. } \omega L = \frac{1}{\omega C} \text{ or } L = \frac{1}{\omega^2 C} \quad \dots(i)$$

Given,

$$\omega = 1000 \text{ s}^{-1}, C = 10 \mu\text{F} = 10 \times 10^{-6} \text{ F}$$

$$\text{Hence, } L = \frac{1}{(1000)^2 \times 10 \times 10^{-6}} = 0.1 \text{ H} = 100 \text{ mH}$$

12 When $\omega L = 1/\omega C$. The circuit is in resonance. Impedance is equal to resistance alone.

$$13 Q = \frac{f_r}{f_2 - f_1} = \frac{5000}{500} = 10$$

14 For better tuning, peak of current growth must be sharp. This is ensured by a high value of quality factor Q.

Now, quality factor is given by

$$Q = \frac{1}{R} \sqrt{\frac{L}{C}}$$

From the given options, highest value of Q is associated with $R = 15 \Omega, L = 3.5 \text{ H}$ and $C = 30 \mu\text{F}$

15 Resonant frequency, $n = \frac{1}{2\pi \sqrt{LC}}$

$$LC = \frac{1}{4\pi^2 n^2} \Rightarrow C = \frac{\lambda^2}{4\pi^2 c^2 L}$$

$$\lambda = \sqrt{4\pi^2 c^2 LC}$$

$$\Rightarrow \lambda = \sqrt{4\pi^2 \times (3 \times 10^8)^2 \times 2.4 \times 10^{-6} \times 10^{-8}}$$

$$\Rightarrow \lambda = 292 \text{ m}$$

16 Given, $\lambda = 300 \text{ m}, c = 3 \times 10^8 \text{ m/s}$

$$\therefore \text{Frequency, } n = \frac{c}{\lambda} = \frac{3 \times 10^8}{300} = 10^6 \text{ Hz}$$

$$\text{Resonance frequency, } n = \frac{1}{2\pi \sqrt{LC}}$$

$$\text{or } \sqrt{LC} = \frac{1}{2\pi n}$$

$$\text{or } LC = \frac{1}{4\pi^2 n^2}$$

Here, $C = 2.4 \times 10^{-6} \text{ F}$

$$\therefore L = \frac{1}{4\pi^2 (10^6)^2 \times 2.4 \times 10^{-6}} = 10^{-8} \text{ H}$$

17 Power factor = $\frac{R}{Z}$

$$P_i = \frac{1}{2} \quad (\because Z = 2R)$$

$$P_f = \frac{1}{4} \quad (\because Z = 4R)$$

The percentage of the impedance will be 100%.

18 For an AC circuit containing capacitor only, the phase difference between current and voltage will be $\frac{\pi}{2}$ (i.e. 90°).

Hence, power in this case is given by

$$P = VI \cos \phi$$

(where, ϕ = phase difference between voltage and current)

$$P = VI \cos 90^\circ = 0$$

19 Power dissipated in series L-C-R,

$$P = I_{\text{rms}}^2 R$$

$$= \frac{\varepsilon_{\text{rms}}^2 R}{|Z|^2} = \frac{\varepsilon^2 R}{\left[R^2 + \left(\omega L - \frac{1}{\omega C} \right)^2 \right]}$$

$$\left[\text{As, } I_{\text{rms}} = \frac{V_{\text{rms}}}{Z} \right]$$

20 Given equation,

$$I = \frac{1}{\sqrt{2}} \sin(100\pi t) \text{ ampere}$$

$$\text{and } e = \frac{1}{\sqrt{2}} \sin(100\pi t + \pi/3) \text{ volt}$$

$$\therefore I_0 = \frac{1}{\sqrt{2}} \text{ and } e_0 = \frac{1}{\sqrt{2}}$$

We know that, average power,

$$P_{\text{av}} = V_{\text{rms}} \times I_{\text{rms}} \cos \phi$$

$$= \frac{1}{2} \times \frac{1}{2} \times \cos 60^\circ$$

$$\left[\because I_{\text{rms}} = \frac{I_0}{2} \text{ and } V_{\text{rms}} = \frac{V_0}{\sqrt{2}} \right]$$

$$= \frac{1}{2} \times \frac{1}{2} \times \frac{1}{2} = \frac{1}{8} \text{ W}$$

21 Power factor of an L-C-R circuit

$$= \cos \phi = \frac{R}{Z}$$

$$= \frac{IR}{IZ} = \frac{80}{I\sqrt{(X_L - X_C)^2 + R^2}}$$

$$= \frac{80}{\sqrt{(100 - 40)^2 + (80)^2}}$$

$$= \frac{80}{\sqrt{(60)^2 + (80)^2}} = \frac{80}{100} = 0.8$$

22 Quantity of heat liberated in the ammeter of resistance R

(i) due to direct current of 3 A

$$= \left(3^2 \frac{R}{J} \right)$$

(ii) due to alternating current of 4 A

$$= \left[4^2 \frac{R}{J} \right]$$

Total heat produced per second

$$= \frac{(3)^2 R}{J} + \frac{(4)^2 R}{J} = \frac{25R}{J}$$

Let the equivalent alternating current be I virtual ampere, then

$$\frac{I^2 R}{J} = \frac{25R}{J} \text{ or } I = 5 \text{ A}$$

23 Here, $X_L = 1 \Omega, R = 2 \Omega, E_V = 6 \text{ V}, P = ?$

$$\therefore Z = \sqrt{X_L^2 + R^2} = \sqrt{1^2 + 2^2} = \sqrt{5} \Omega$$

$$\therefore I_V = \frac{E_V}{Z} = \frac{6}{\sqrt{5}} \text{ A}$$

$$\therefore P = E_V I_V \cos \theta$$

$$= 6 \times \frac{6}{\sqrt{5}} \times \frac{2}{\sqrt{5}}$$

$$= 14.4 \text{ W}$$

24 Power output = $3 \text{ kW} \times \frac{90}{100} = 2.7 \text{ kW}$

$$I_b = 6 \text{ A}$$

$$V_S = \frac{2.7 \text{ kW}}{6 \text{ A}} = 450 \text{ V}$$

$$I_P = \frac{3 \text{ kW}}{200 \text{ V}} = 15 \text{ A}$$

25 Efficiency is defined as the ratio of output power and input power,

$$\text{i.e. } \eta \% = \frac{P_{\text{out}}}{P_{\text{input}}} \times 100$$

$$= \frac{V_s i_s}{V_p i_p} \times 100$$

$$80 = \frac{2 \times 440}{220 \times i_p} \times 100$$

$$\Rightarrow i_p = 5 \text{ A}$$



SESSION 2

$$1 \quad I = \frac{V}{R} = \frac{30}{10} \sin 50t + \frac{40}{10} \cos 50t$$

$$I = 3 \sin 50t + 4 \cos 50t$$

$$\Rightarrow I = 5 \left[\frac{4}{5} \cos 50t + \frac{3}{5} \sin 50t \right]$$

$$= 5 [\cos 37^\circ \cos 50t + \sin 37^\circ \sin 50t]$$

$$= 5 \cos [50t - 37^\circ]$$

Now, $I_{\text{rms}} = \frac{I_0}{\sqrt{2}} = \frac{5}{\sqrt{2}} \text{ A}$

$$2 \quad I = \frac{P}{V} = \frac{60}{10} = 6 \text{ A}$$

$$\Rightarrow V = \sqrt{V_R^2 + V_L^2}$$

$$(100)^2 = (10)^2 + V_L^2$$

$$\Rightarrow V_L = 99.5 \text{ V}$$

$$V_L = IX_L = I(2\pi \nu L)$$

$$99.5 = 6 \times 2 \times 3.14 \times 50 L$$

$$\Rightarrow L = 0.052 \text{ H}$$

$$3 \quad V = V_0 \sin \omega t \quad [\text{as, } V = 0 \text{ at } t = 0]$$

$$V_R = V_0 \sin \omega t$$

$$V_C = V_0 \sin \left(\omega t - \frac{\pi}{2} \right)$$

V and V_R are in same phase. While V_C lags V (or V_R) by 90° . Now, V_R is in same phase with initial potential difference across the capacitor for the first time when

$$\omega t = -\frac{\pi}{2} + 2\pi = \frac{3\pi}{2} \Rightarrow t = \frac{3\pi}{2\omega}$$

$$4 \quad Z = \sqrt{(3)^2 + (4)^2} = 5 \Omega$$

$$I_0 = \frac{10}{Z} = 2 \text{ A}$$

$$\phi = \tan^{-1} \left(\frac{X_L}{R} \right) = \tan^{-1} \left(\frac{4}{3} \right) = 53^\circ$$

$$\therefore I = 2 \sin (\omega t - 53^\circ)$$

$$\text{At } t = \frac{\pi}{\omega} \text{ or } \omega t = \pi,$$

$$I = 2 \sin (\pi - 53^\circ)$$

$$= 2 \times \frac{4}{5} = 1.6 \text{ A}$$

$$V_R = IR = 4.8 \text{ V}$$

5 Power factor of AC circuit is given by

$$\cos \phi = \frac{R}{Z} \quad \dots(i)$$

where, R is resistance employed and Z the impedance of the circuit.

$$Z = \sqrt{R^2 + (X_L - X_C)^2} \quad \dots(ii)$$

From Eqs. (i) and (ii), we get

$$\cos \phi = \frac{R}{\sqrt{R^2 + (X_L - X_C)^2}} \quad \dots(iii)$$

$$\text{Given, } R = 8 \Omega, X_L = 31 \Omega, X_C = 25 \Omega$$

$$\therefore \cos \phi = \frac{8}{\sqrt{(8)^2 + (31 - 25)^2}}$$

$$= \frac{8}{\sqrt{64 + 36}}$$

$$\text{Hence, } \cos \phi = 0.80$$

6 Charge on capacitor, $q_0 = CV$

$$q_0 = 2 \times 10^{-6} \text{ C}$$

$$q = q_0 \sin \omega t$$

For maximum current,

$$I_0 = \frac{dq}{dt} = \omega q_0$$

$$\text{Also, } \omega = \frac{1}{\sqrt{LC}} = (10^9)^{1/2}$$

$$I_0 = (10^9)^{1/2} (2 \times 10^{-6})$$

$$= \sqrt{10} \times 10^4 \times 2 \times 10^{-6}$$

$$= 2\sqrt{10} \times 10^{-2} \text{ A}$$

$$= \sqrt{4000} \text{ mA}$$

7

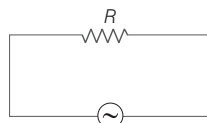

$$P_0 = V_{\text{rms}} I_{\text{rms}} = V_{\text{rms}} \frac{V_{\text{rms}}}{R}$$

$$\left[\because V_{\text{rms}} = I_{\text{rms}} R \Rightarrow \frac{V_{\text{rms}}}{R} = I_{\text{rms}} \right]$$

$$P_0 = \frac{V_{\text{rms}}^2}{R}$$

$$\Rightarrow V_{\text{rms}}^2 = P_0 R$$

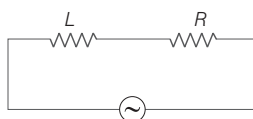

$$P = V_{\text{rms}} I_{\text{rms}} \cos \phi$$

$$= V_{\text{rms}}^2 \frac{R}{Z^2} = P_0 R \frac{R}{Z^2}$$

$$P = P_0 \frac{R^2}{Z^2}$$

8 Here, phase difference,

$$\tan \phi = \frac{X_L - X_C}{R}$$

$$\Rightarrow \tan \frac{\pi}{3} = \frac{X_L - X_C}{R}$$

When L is removed, then

$$\sqrt{3} = \frac{X_C}{R} \Rightarrow X_C = \sqrt{3} R$$

When C is removed, then

$$\sqrt{3} = \frac{X_L}{R} \Rightarrow X_L = \sqrt{3} R$$

$$Z = \sqrt{R^2 + (X_L - X_C)^2} = R$$

$$[\because X_L = X_C]$$

$$\cos \phi = \frac{Z}{R} = \frac{R}{R} = 1$$

9 Current in the circuit is given by

$$I = \frac{E}{\sqrt{\omega^2 L^2 + R^2}}, \text{ where } E \text{ is the voltage}$$

of an AC source

$$\text{As } L = \frac{\mu_0 \mu_r N^2 A}{l} \Rightarrow L \propto \mu_r$$

When iron rod is inserted, L increases, therefore current I decreases.

10 Given, inductance, $L = 20 \text{ mH}$

Capacitance, $C = 50 \mu\text{F}$

Resistance, $R = 40 \Omega$

emf, $V = 10 \sin 340t$

\therefore Power loss in AC circuit will be given as

$$P_{\text{av}} = I_V^2 R = \left[\frac{E_V}{Z} \right]^2 \cdot R \quad \left[\because I_V = \frac{E_V}{Z} \right]$$

$$= \left(\frac{10}{\sqrt{2}} \right)^2 \cdot 40$$

$$= \frac{1}{40^2 + \left(\frac{340 \times 20 \times 10^3}{340 \times 50 \times 10^{-6}} \right)^2}$$

$$= \frac{100}{2} \times 40 \times \frac{1}{1600 + (6.8 - 58.8)^2}$$

$$= \frac{2000}{1600 + 2704} \approx 0.46 \text{ W} \approx 0.51 \text{ W}$$

$$11 \quad \tan \phi = \frac{\omega L - \frac{1}{\omega C}}{R}$$

ϕ being the angle by which the current leads the voltage.

Given, $\phi = 45^\circ$

$$\therefore \tan 45^\circ = \frac{\omega L - \frac{1}{\omega C}}{R} \Rightarrow 1 = \frac{\omega L - \frac{1}{\omega C}}{R}$$

$$\Rightarrow R = \omega L - \frac{1}{\omega C} \Rightarrow \omega C = \frac{1}{(\omega L - R)}$$

$$\Rightarrow C = \frac{1}{\omega(\omega L - R)} = \frac{1}{2\pi f(2\pi fL - R)}$$

12 In position 1,

$$\tan \frac{\pi}{6} = \frac{\omega L}{R} = \frac{(1000)(\sqrt{3} \times 10^{-3})}{R}$$

$$\Rightarrow \frac{1}{\sqrt{3}} = \frac{\sqrt{3}}{R} \Rightarrow R = 3 \Omega$$

$$\text{In position 2, } \tan \phi = \frac{X_C}{R} = \left(\frac{1}{\omega C} \right)$$

$$\tan \phi = \frac{1}{\frac{1000 \times \frac{1000}{3} \times 10^{-6}}{3}} = 1$$

$$\Rightarrow \phi = \frac{\pi}{4}$$

13

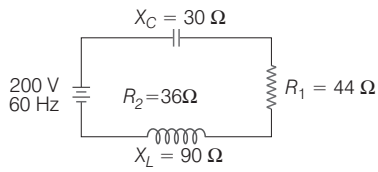

$$X_L = 90 \Omega, R_2 = 36 \Omega, X_C = 30 \Omega$$

and total resistance,
 $R = R_1 + R_2 = 44 + 36 = 80 \Omega$

$$Z = \sqrt{R^2 + (X_L - X_C)^2} = \sqrt{(80)^2 + (60)^2}$$

$$Z = \sqrt{6400 + 3600} = 100$$

Current, $I = \frac{V}{Z} = \frac{200}{100} = 2 \text{ A}$

Power dissipated in the coil,

$$P_{av} = I^2 R = (2)^2 \times 80 = 320 \text{ W}$$

14 (*) No option is matching.

Thinking Process Just after switch is closed, inductor acts like a closed switch (closed path) and capacitor acts like an open switch (open path), because in DC circuit, inductive resistance becomes zero.

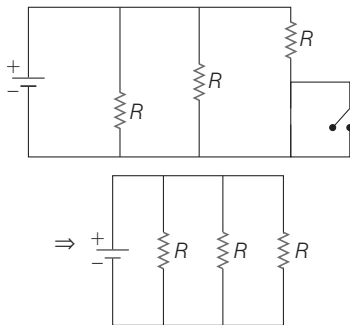

So, equivalent resistor = $\frac{R}{3} = \frac{9}{3} \Omega = 3 \Omega$

Battery emf, $V = 18 \text{ V}$

$$\therefore \text{Current in circuit} = \frac{V}{R} = \frac{18}{3} = 6 \text{ A}$$

15 Net reactive capacitance,

$$X_C = \frac{1}{2\pi fC}$$

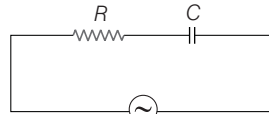

$$V = V_0 \sin \omega t$$

So, current in circuit,

$$I = \frac{V}{Z} = \frac{V}{\sqrt{R^2 + \left(\frac{1}{2\pi fC}\right)^2}}$$

$$\Rightarrow I = \frac{2\pi fC}{\sqrt{4\pi^2 f^2 C^2 R^2 + 1}} \times V$$

Voltage drop across capacitor,

$$V_C = I \times X_C = \frac{2\pi fC \times V}{\sqrt{4\pi^2 f^2 C^2 R^2 + 1}} \times \frac{1}{2\pi fC}$$

$$\text{i.e. } V_C = \frac{V}{\sqrt{4\pi^2 f^2 C^2 R^2 + 1}}$$

When mica is introduced, capacitance will increase, hence voltage across capacitor get decrease.

16 (c) Here, inductance,

$$L = 20 \text{ mH} = 20 \times 10^{-3} \text{ H}$$

$$\text{Capacitance, } C = 100 \mu\text{F} = 100 \times 10^{-6} \text{ F}$$

Resistance, $R = 50 \Omega$

emf, $V = 10 \sin 314t$

\therefore The general equation of emf is given as

$$V = V_0 \sin \omega t$$

\therefore Comparing Eqs. (i) and (ii), we get

$$V_0 = 10 \text{ V}, \omega = 314 \text{ rad s}^{-1}$$

The power loss associated with the given AC circuit is given as

$$P = V_{\text{rms}} I_{\text{rms}} \cos \phi = V_{\text{rms}} \left(\frac{V_{\text{rms}}}{Z}\right) \left(\frac{R}{Z}\right) = \left(\frac{V_{\text{rms}}}{Z}\right)^2 R = \left(\frac{V_0}{\sqrt{2} \cdot Z}\right)^2 R \quad \dots(i)$$

$$\therefore \text{Impedance, } Z = \sqrt{R^2 + (X_L - X_C)^2} = \sqrt{R^2 + \left(\omega L - \frac{1}{\omega C}\right)^2}$$

\therefore Substituting the given values in the above equation, we get

$$= \sqrt{(50)^2 + \left[\frac{(314 \times 20 \times 10^{-3})^2}{1} - \frac{1}{314 \times 10^{-4}} \right]^2} = \sqrt{2500 + [6280 \times 10^{-3} - 0.00318 \times 10^4]^2} = \sqrt{2500 + (25.56)^2} = 56.15 \Omega \approx 56 \Omega$$

Now, substituting this values in Eq. (i), we get

$$P = \left(\frac{10}{\sqrt{2} \times 56}\right)^2 \times 50 = \frac{100}{2 \times 3136} \times 50 = 0.79 \text{ W}$$

Thus, power loss in the circuit is 0.79 W.